

Poles

Product Brochure



Busck's operations are ISO9001 certified as well as being a Certified Plant meeting the high standards set by Concrete NZ.

Busck is New Zealand's leading Concrete power pole supplier. We supply poles and associated products to most electricity lines companies in New Zealand and have also supplied poles to Australia and the Pacific Islands. We pride ourselves on producing high quality, high strength prestressed concrete products.



General

Our products include a complete range of high strength "I" section prestressed concrete power poles, pole base blocks (donuts), breast and heel blocks, stay blocks and a complete range of transformer and switchgear pads for all types available in New Zealand. Busck provides technical support and training to all customers within the electricity infrastructure industry. Busck provides a number of transport options, both within New Zealand and internationally.

Durability

Busck's prestressed concrete poles and associated products are typically manufactured to achieve 60 years design life in exposure classifications A2, B1 & B2 prescribed in section 3 of the New Zealand standard NZS3101:Part 1:2006 as well as AS/NZS7000:2016. Special attention is necessary in more extreme environments, such as coastal marine areas or in aggressive soils.

Concrete poles out perform timber pole alternatives without the environmental impact of harmful toxins or deforestation of slow growing imported hardwood species.

Fire

As a material, concrete performs well in a fire. There have been numerous incidents where bush fires or events have proved their worth compared to other material options.

Prestressed Concrete Poles

Busck first started manufacturing concrete power poles over 40 years ago. In 1999 Busck updated their pole designs to meet the then draft standard AS/NZS4065.

Our current pole sizes range from 7.5m up to 18.5m long. All poles are fitted with equipotential bonding points, which meet the requirements of the EEA's guide for working on de-energised lines. Busck poles can be supplied with or without the added safety option of paint and reflectors before leaving the factory. Busck poles are prefitted with six digit uniquely numbered asset id.

All Busck poles are manufactured to AS/NZS 4065, AS/NZS7000 and are tested to AS/NZS 4676.

Busck pole ratings are based on ultimate limit state strength across line and most have an along line rating of at least 30% of the across line rating. This feature exceeds that required in AS/NZS4065 and along with the poles flexibility, assist to limit cascade failure. All rates are ultimate limit state. Busck poles are used at voltages from 230V up to 110kV lines across New Zealand, from the winterless north to heavy snow and frost areas of the South.



Name	Length	Height	TLC		Mass
			Across line	Along line	
	(m)	(m)	(kN)	(kN)	(kg)
B9.5	9.5	7.9	13	4	750
B10.0	10	8.2	26	8	1222
B11.0	11	9.2	22	8	1290
B11.5	11.5	9.4	26	8	1532
B12.5	12.5	10.4	22	7	1600
B15.5	15.5	12.3	32	8	2750
B14.85 (14.0m)	14.85	11.65	34	9	2650
B13.65 (12.5m)	13.65	10.45	38	10	2500
B12.4 (11.0m)	12.4	9.2	43	11	2300
B18.5	18.5	15.2	32	8	4100
B15.6 (15.5m)	15.6	12.3	40	10	3800
B14.95 (14.0m)	14.85	11.65	41.75	10.4	3700

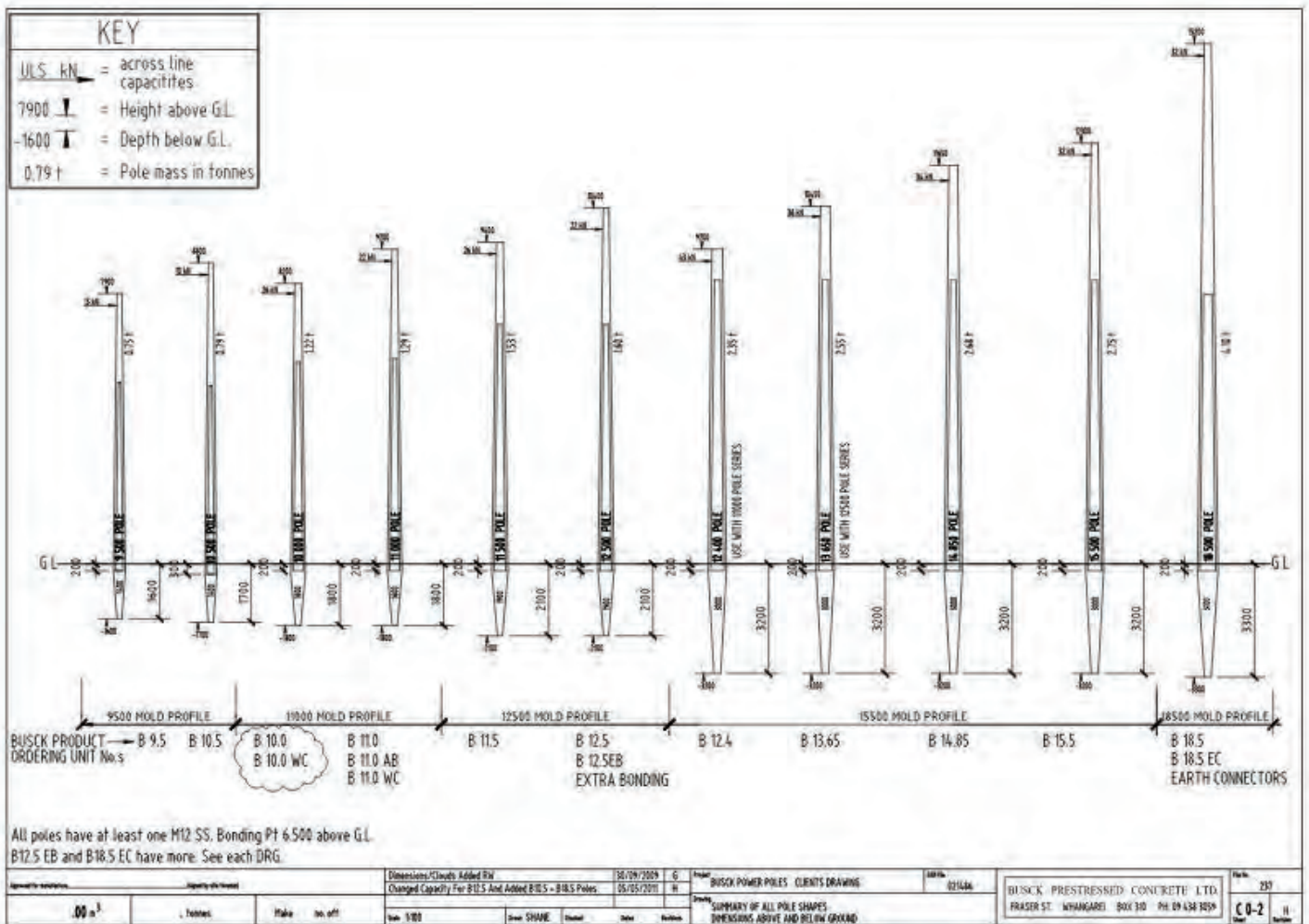

Tip Loadings

Busck's prestressed poles are designed in-house and proven through testing to have the capacity tabulated. The tip capacities listed are the failure loads or ultimate limit state. The ultimate loads are divided by two to represent serviceability or working loads for your line designs.

Our testing meets the criteria of maximum deflection and 0.25mm crack width at working load.



Handling and Storage

Busck prestressed concrete poles are designed to be lifted about a balance point as well as the tip for vertical alignment during installation. Specially designed Reid Swiftlift type lifting anchors are cast in or strops are used with a bolt through a cast-in hole attached to the chain at the tip.

Busck poles are labelled to provide the installation contractor with the pole's weight for selecting adequate lifting equipment.

If the units are stored on site they will need to be dunnaged near 1/5 x the length from each end for 1 poles. If stacking the poles dunnage blocks need to be aligned on top of each other so as to not induce large point loads on the poles below. Care needs to be taken as to the suitability of the ground and dunnage block to resist the weight of the units stored on top.

All lifting gear should be checked for any wear or damage regularly as concrete elements can be abrasive.

Refer to our "Guideline for Safe Handling of Concrete Poles and Foundation Blocks," on the Busck website.



Equipotential Bonding

A fatality in 2006 highlighted an issue with linemen working on de-energised conductors supported on concrete poles. One of the conductors contacted an adjacent live circuit and although portable earths had been applied to the conductors, a lineman who was in contact with a conductor and the pole received a fatal electric shock. The applied portable earths failed to protect the lineman because the voltage at the portable earth pin and the voltage at the base of the pole were significantly different.

To overcome this situation it has been determined that bonding the portable earth to the reinforcing steel in the pole will create an equipotential zone protecting anyone working on that pole.

Busck manufacture poles and associated products with a ferrule set into the concrete that is connected to steel reinforcement inside the pole. Tests have been conducted to confirm:

- 1) That the likely fault currents do not damage the pole and that the bonding ferrule connection to the steel has adequate capacity.
- 2) That a satisfactory equipotential zone is created by connecting the portable earth star point to the bonding ferrule of the poles.

Tests proved Busck's poles are suitable for at least 1000amps for a period of 24 seconds.





Electricity Hardware

Busck poles can be doubled up to provide twice the capacity for supporting transformers and various line configurations. Refer to our “Guideline for Safe Handling of Concrete Poles and Foundation Blocks,” on the Busck website. Stay poles are also available.

Surface Finishes

NZS3114:1987 prescribes the descriptions and tolerances for formed finishes “F1” to “F6” and manual finishes “U1” to “U11” eg. “U5” for broomed rough top surface quality. Concrete surfaces are influenced by quality of vibration, trowelling and mould material used in production. Cost increases as the expectations of the quality of the surface improves.

Busck’s products generally achieves, at worst, “F4” finish off a steel mould and “U3” steel trowell to manually finished surfaces.



Associated Products



Electricity Associated Concrete Products







To complement the pole range, Busck also manufactures a wide range of precast concrete products associated with the electricity supply industry. These include pole base blocks (donuts), breast and heel blocks, switch handle earth pads, and stay blocks.





Busck manufacture a complete range of transformer and switchgear pads for all New Zealand transformer and switchgear suppliers. Included in Busck's range are switchgear foundations designed to meet New Zealand seismic requirements.

Busck also manufacture customised products to meet our customer's needs.



Product number	Description	Dimensions Weight Factory	Photo
BB600	Pole Breast Block – 600 Minimum Order Qty: 30	600mm x 360mm 54kg WH, NG, PN, IN	
BB900	Pole Breast Block – 900 Minimum Order Qty: 15	900mm x 360mm 81kg WH, NG, PN, IN, CH	
BB1200	Pole Breast Block -1200 Minimum Order Qty: 15	1200mm x 360mm 110kg WH, NG, PN, IN	



HB460	Pole Heel block – 460mm Minimum Order Qty: 20	460mm x 350mm 40kg NG, PN, IN	
SB900	Pole Stay Block – 900mm Minimum Order Qty: 25	900mm x 200mm 50kg PN, NG	
SB1200	Pole Stay Block – 1200mm Minimum Order Qty: 12	1200mm x 150mm 45Kg WH	
D490BK	Busckcrete donut - 490mm	490mmØ x 225mm 25kg	
D460	Pole Single Donut – 460mm Minimum Order Qty: 8	460mmØ x 225mm 60kg PN	
D490	Pole Single Donut – 490mm Minimum Order Qty: 8	490mmØ x 225mm 90kg WH, NG, PN, IN, CH	
D490LT	Pole Single Donut – 490mm light Minimum Order Qty: 10	490mmØ x 120mm 50kg WH, PN, IN	
DD540	Pole Double Donut – 540mm Minimum Order Qty: 4	540mmØ x 300mm 120kg WH, NG, PN, IN	

D540	Pole Single Donut - 540mm (15.5m pole) Minimum Order Qty: 4	540mmØ x 225mm 107kg WH	
DD840	Pole Double Donut 840mm (15.5m pole) Minimum Order Qty: 2	840mmØ x 300mm 315kg WH	
FB450	Pole Flintstone Stay Block - 450mm Minimum Order Qty: 20	450mmØ x 150mm 60kg IN	
EP600E	Pole Switch Earth Pad - 600mm Minimum Order Qty: 10	600mm x 600mm 40kg WH, IN	

Switchgear Pads

ABB SafeLink Switchgear



Top Pads for Safelink switches available direct from ABB. These will fit directly on the Busck foundation walls. The Busck foundation has been design for earthquake loadings to suit most of New Zealand, please check with Busck if your location is suitable.

SLKIT1	Safelink CFC/CCC Pad Assembly Minimum Order Qty: 1	1700mm x 1225mm x 950mm 1900kg WH, IN	
SLKIT2	Safelink CFCC/CCCC Pad Assembly Minimum Order Qty: 1	1700mm x 1225mm x 950mm 1900kg WH, IN	

SLKIT3	Safelink CFCF Pad Assembly Minimum Order Qty: 1	1700mm x 1225mm x 950mm 2100kg WH, IN	
--------	--	---	--

Halo Switchgear

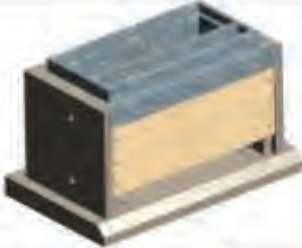
Top steel plinth are purchased from ADR, but delivered with Busck foundation







HALO3	Halo 3 way Assembly - Minimum Order Qty: 1	1488mm x 1105mm x 1000mm 1511kg WH	
HALO4	Halo 4 way Assembly - Minimum Order Qty: 1	1838mm x 1105mm x 1000mm 1772kg WH	
HALO5	Halo 5 way Assembly - Minimum Order Qty: 1	2188mm x 1105mm x 1000mm 2033kg WH	
HALO6	Halo 5 Way Assembly - Minimum Order Qty: 1		





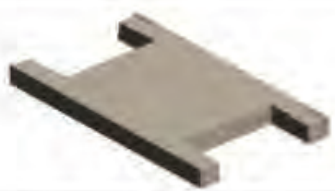

Scheider Switchgear



RMU1200	Switchgear Base Ring Master RGM3-40 Minimum Order Qty: 1	1100mm x 1200mm 388kg WH	
RMU1500	Switchgear Base Ring Master RGM3-41 Minimum Order Qty: 1	1500mm x 1200mm 453kg WH	

Transformer Pads

ABB and Etel

MSP1320ED	Transformer Pad Micro Sub 15-50 KVA Minimum Order Qty: 1	1320mm x 1150mm 440kg IN, <u>South Island only</u>	
MSP1350ED	Transformer Pad Micro Sub 15-75 KVA Minimum Order Qty: 1	1350mm x 1150mm 550kg WH, <u>North Island only</u>	
MSP1560ED	Transformer Pad Micro Sub Pad 75-100KVA Minimum Order Qty: 1	1560mm x 1150mm 550kg IN, WH	
CP1600E	Transformer Pad Etel City Pad 100-500 KVA Minimum Order Qty: 1	1600mm x 1600mm 800kg WH	
CP1800E	Transformer Pad ABB front entry 300-500 KVA Minimum Order Qty: 1	1800mm x 1700mm 810kg WH	
MSP2050	Transformer pad Mini Sub 100/300kVA Minimum Order Qty: 1	2050 mm x 1300mm x 150mm 800kg IN, <u>South Island only</u>	
MSP2250ED	Transformer pad Mini Sub 100/300kVA Minimum Order Qty: 1	2250mm x 1300mm x 150mm 800kg IN, <u>South Island only</u>	
MSP2250EDT	Transformer pad Mini Sub 100/500kVA Minimum Order Qty: 1	2250mm x 1300mm x 200mm 1040kg WH, <u>North Island only</u>	

MSP2250ED	Transformer pad Mini Sub 100/300kVA Minimum Order Qty: 1	2250mm x 1300mm x 150mm 800kg IN, <u>South Island only</u>	
MSP2250EDT	Transformer pad Mini Sub 100/500kVA Minimum Order Qty: 1	2250mm x 1300mm x 200mm 1040kg WH, <u>North Island only</u>	
MSP2400ED	Transformer pad Mini Sub 500kVA Minimum Order Qty: 1	2400mm x 1300mm 840kg <u>South Island only</u>	
MSP2500ED	Transformer pad Mini Sub 750-1000kVA (wide) Minimum Order Qty: 1	2500mm x 1600mm 1150kg WH, IN	
MSP2740ED	Transformer Pad Mini Sub 1500KVA earth/duct Minimum Order Qty: 1	2740mm x 1600mm 1620kg WH	
MSTP2740ED	Transformer pad Total Pad with Safelink2 Switch 100 – 500kVA Minimum Order Qty: 1	2740mm x 1600mm 1610kg WH	
MSTP2935ED	Transformer Pad Total Pad with Safelink2 Switch 750-1000kVA Minimum Order Qty: 1	2935mm x 1600mm x 175mm 1610kg WH, IN	

AFP2276ED	Transformer Arc Fault Pad 500kVA		 A 3D perspective view of a Transformer Arc Fault Pad. It is a flat, rectangular metal plate with a central rectangular cutout. The cutout is slightly offset from the center, with a longer section extending towards the right side. The plate has a uniform thickness and a metallic, light-colored finish.
BPSTEP	Busck Pole Step		 A 3D perspective view of a Busck Pole Step. It is a U-shaped metal component with a flat, horizontal base and two vertical, slightly curved side flanges. The flanges are positioned to form a channel or step. The component has a uniform thickness and a metallic, light-colored finish.



Whangarei

8 Fraser Street
Whangarei 0110
phone: 09 438 3059

Palmerston North

116 Kaimanawa Street
Kelvin Grove 4414
phone: 027 600 5560

Ashburton

7 Malcolm McDowell Road
Ashburton 7772
phone: 03 928 8013

Hamilton

20 Herschel Street
Ngaruawahia 3720
phone: 027 558 9172

Christchurch

257 Annex Road
Middleton 8024
phone: 027 287 5005

Invercargill

4 Lake Street
Cliffon
phone: 027 246 8172

January 2020

DISCLAIMER: Information contained in this brochure is subject to change, consult Busck Prestressed Concrete for further information.

email: info@busck.co.nz

BUSCK website: <http://busck.co.nz/>